

UNI-6006

UNI6006 tag is a compact, flexible label that can be stuck on metallic assets, especially for irregular and uneven surfaces; it has good performance on the metal surface and can be printed and encoded by a Industrial printer.

They offer an extended reading range, making them competent for disparate application areas.

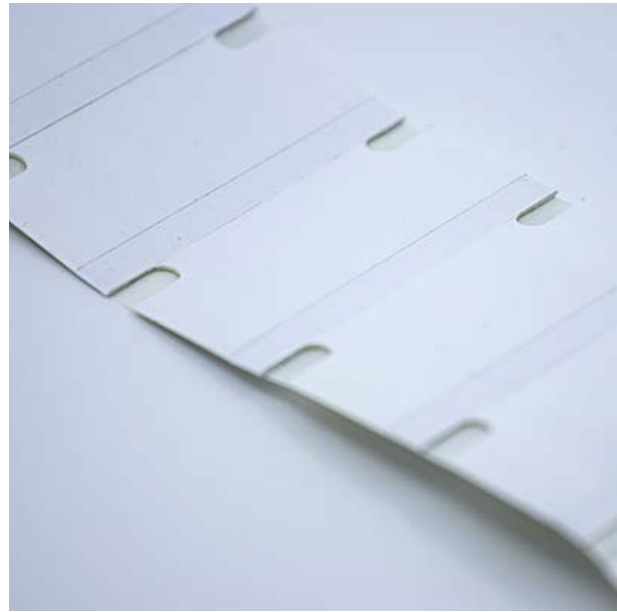

Applications



Asset Management



Retail Management



Warehouse Management

Ordering Information:

Part Number	IC Type	Memory Configuration	Face Material
RFMO-250209-ETSI/FCC	M730	EPC Memory - 128 bits	Polyester
RFMO-250509-ETSI/FCC	NXP UCODE9	EPC Memory - 96 bits	Polyester

For other versions, additional information, and technical support, contact Perfect ID..



Electrical Specifications

Operational Frequency	FCC: 902-928MHz ETSI: 865- 868 MHz
Interface Protocol	ISO 18000-63 and EPCglobal Gen2v2
Chip Type*	IMPINJ M730
Memory Configuration	EPC Memory - 96 bits
Data Retention	50 Years
Write Cycle Endurance	100,000 cycles
Read Range**	upto 4 Meter

Product characteristics

Die Cut Size	60.0 X 06.0 X 1.0 mm / 2.36 X 0.23 X 0.03 in
Face Material	Synthetic Polyester
Packaging	Reel core inner dimension: 76.2mm/3", 500pcs/roll
Yield	100 %
Attachment	Adhesive

Product Drawing

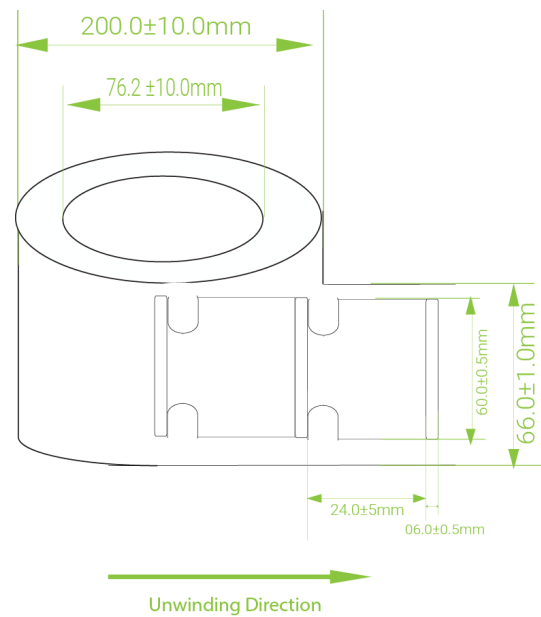

Environmental Specifications

Operating Temperature	-30 to +80 °C
Storage Temperature	-30 to +80 °C
IP Rating	IP 68 , test for 5 hr at 1m deep water

Personalization

- Customer specific encoding of EPC .
- Customised printing of logo, text, barcode ,etc.

READ RANGE GRAPH

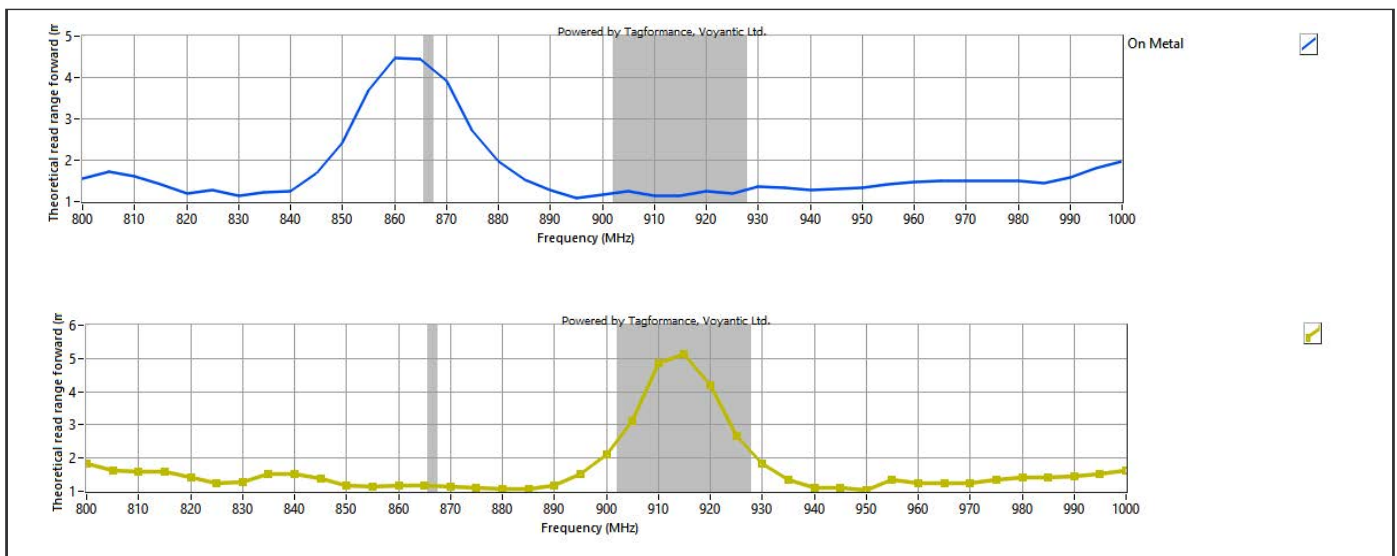

UNI 6006- RF performance(M730)

** The indicated read range values are measured in our laboratory testing environment, where antennas with optimum directivity are used with maximum allowed operating power. Different surface materials and environments may exhibit different results.